

VİNÇ YÜRÜYÜŞ SİSTEMLERİ

Travel Drive Systems



- ✓ **Kompakt tasarım**
Compact design
- ✓ **Estetik görünüm**
Aesthetic look
- ✓ **dayanıklı tekerlek yatakları**
Highly durable wheel bearings
- ✓ **Soketli motor bağlantısı**
Simple Sockets /Plugs used for connections
- ✓ **Göbekten tahrik sistemi**
Direct Drive System
- ✓ **Kolay montaj**
Easy installation



GTS Başlık Kiriş Genel Parça Çizelgesi

(2 Nolu Bağlantı Şekli)
Direct drive, end truck carriage general parts drawing.

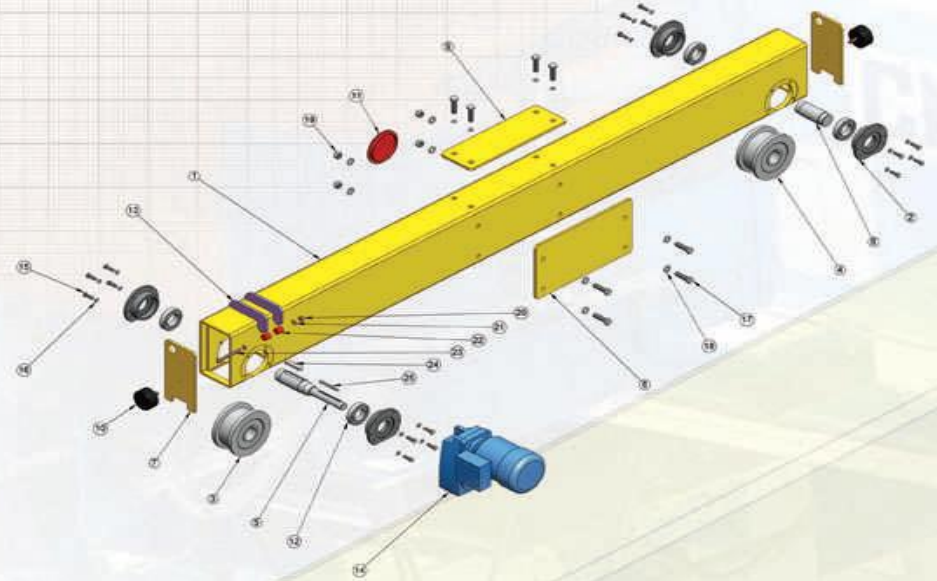

KİT NO	PARÇA ADI / TR	GTS125		GTS160		GTS200		GTS250		GTS315	
		ADET (MONORAY)	ADET (OPTİYON)	ADET (MONORAY)	ADET (OPTİYON)	ADET (MONORAY)	ADET (OPTİYON)	ADET (MONORAY)	ADET (OPTİYON)	ADET (MONORAY)	ADET (OPTİYON)
1	BALIK KİRİŞİ	1	1	1	1	1	1	1	1	1	1
2	GTS TEKER KARKAS	4	4	4	4	4	4	4	4	4	4
3	SARMSIZ TEKERLEK	1	1	1	1	1	1	1	1	1	1
4	SARMSIZ TEKERLEK	1	1	1	1	1	1	1	1	1	1
5	SARMSIZ TEKERLEK	1	1	1	1	1	1	1	1	1	1
6	SARMSIZ TEKERLEK	1	1	1	1	0	0	1	1	1	1
7	TAMPAK PLAKASI	2	2	2	2	2	2	2	2	2	2
8	KOPRİ ALIN BİLEK PLAKASI	1	2	1	2	1	2	1	2	1	2
9	YERELİ SİTEYON	2	2	2	2	2	2	2	2	2	2
10	MONTAJ KARKAS	1	2	1	2	1	2	1	2	1	2
11	BULGARI	10/20/30	10/20/30	4	4	4	4	4	4	4	4
12	MOTOR BAĞLANTI KESİLEBİ	2	2	2	2	2	2	2	2	2	2
13	YERELİ MOTOR REDÜKTÖRÜ	1	1	1	1	1	1	1	1	1	1
14	GTS TEKER KARKAS BAĞLANTISI	12	12	16	16	18	18	18	18	18	18
15	GTS TEKER KARKAS BAĞLANTISI	12	12	16	16	18	18	18	18	18	18
16	KOPRİ BAĞLANTI BAĞLANTISI	8	16	8	16	8	16	8	16	8	16
17	KOPRİ BAĞLANTI BAĞLANTISI	8	16	8	16	8	16	8	16	8	16
18	KOPRİ BAĞLANTI BAĞLANTISI	8	16	8	16	8	16	8	16	8	16
19	MOTOR BAĞLANTI BAĞLANTISI	1	1	1	1	1	1	1	1	1	1
20	MOTOR BAĞLANTI BAĞLANTISI	1	1	1	1	1	1	1	1	1	1
21	MOTOR BAĞLANTI BAĞLANTISI	2	2	2	2	2	2	2	2	2	2
22	MOTOR BAĞLANTI BAĞLANTISI	1	1	1	1	1	1	1	1	1	1
23	GTS TEKER KARKAS	2	2	2	2	2	2	2	2	2	2
24	GTS TEKER KARKAS	2	2	2	2	2	2	2	2	2	2
25	KOPRİ BAĞLANTI BAĞLANTISI	1	2	1	2	1	2	1	2	1	2